

WRC2430,WRC3018

ASSEMBLY INSTRUCTIONS

Getting started:

prepare a protection layer, a screwdriver

STEP 1: Join side panel with back panel.

STEP 2: Join side panels with back panel and attach top panel for support.

STEP 3: Join bottom panel with side panels and back panel.

STEP 4: Attach the wine rack to side panels.

STEP 5: Attach front face-frame on.

PARTS LIST		
NO.	Description	QTY
1	WINE RACK	2
2	FACE FRAME	1
3	BACK PANEL	1
4	SIDE PANEL	2
5	TOP&BOTTOM PANEL	2

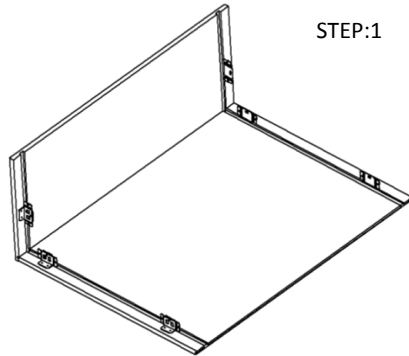
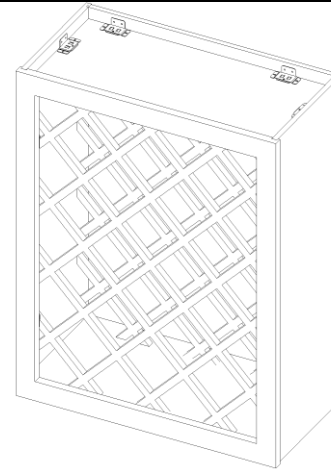

STEP:1

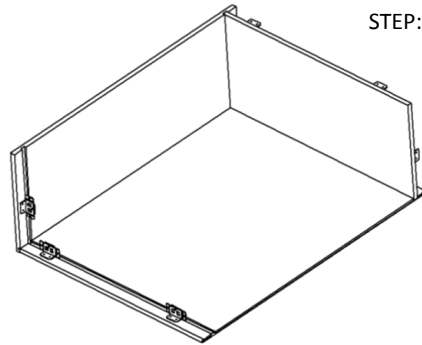

STEP:2

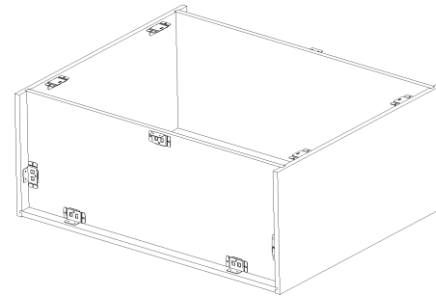

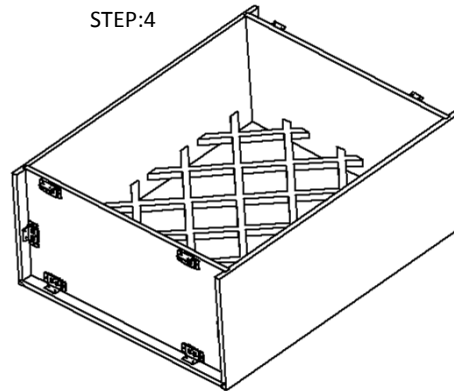

STEP:3

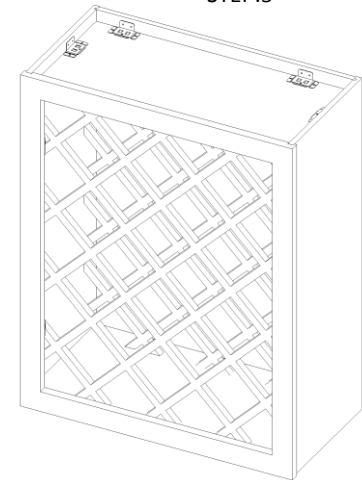

STEP:4



STEP:5

3	9/16"ROUND HEAD SCREW	60	 9/16" round head screw
2	CLEAT AND BUCKLE	12	 Cleat and Buckle
1	1"FLAT HEAD SCREW FOR CARCASS	12	 1" flat head screw
NO.	Description	QTY	PICTURE

HARDWARE LIST