

W0930,W1230,W1530,W1830,W2130  
 W0936,W1236,W1536,W1836,W2136  
 W0942,W1242,W1542,W1842,W2142

ASSEMBLY INSTUCTIONS

Getting started:

Prepare a solid surface with protection layer to assemble on.

STEP 1: Join side panel with back panel.

STEP 2: Join side panels with back panel and attach top panel for support.

STEP 3: Join bottom panel with side panels and back panel.

STEP 4: Attach face-frame on.

STEP 5: Put in the adjustable shelves.





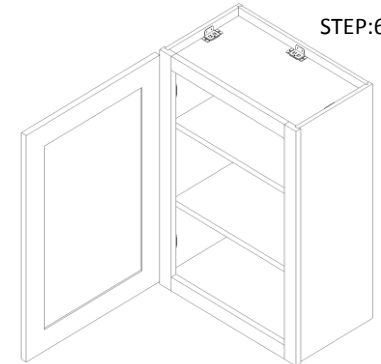
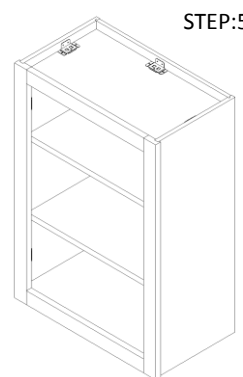
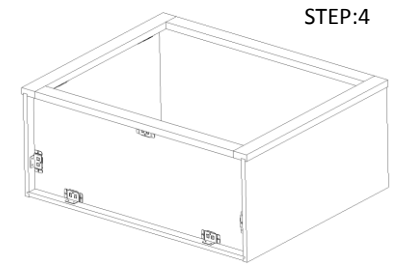
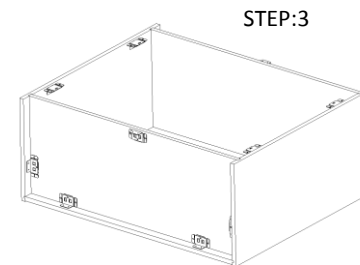
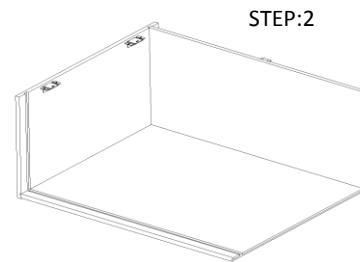
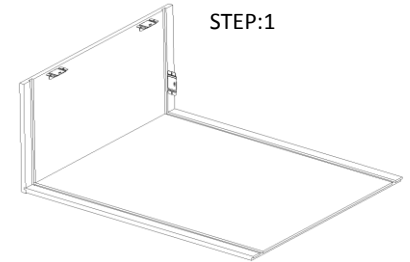
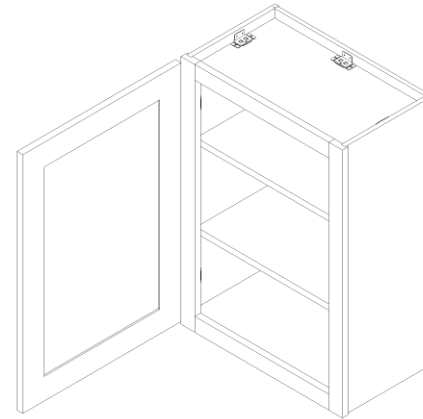

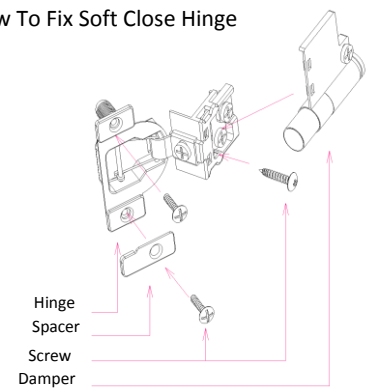

STEP 6: Fix door onto the face-frame and adjust the cover-space.

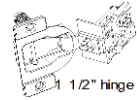
PARTS LIST		
NO.	Description	QTY
1	FACE FRAME	1
2	BACK PANEL	1
3	ADJUSTABLE SHELF	2 OR 3
4	SIDE PANEL	2
5	TOP&BOTTOM PANEL	2
6	CABINETS DOOR	1



How To Fix Soft Close Hinge



8	1 1/2" SOFTCLOSE HINGE	2	
7	3/4" ROUND HEAD SCREW	2	
6	BUMPER	2	
5	DAMPER	1	
4	SHELF CLIP	8	
3	9/16"ROUND HEAD SCREW	50	
2	CLEAT AND BUCKLE	10	
1	1"FLAT HEAD SCREW FOR CARCASS	4	
NO.	Description	QTY	PICTURE

HARDWARE LIST