

W3012,W3612,W3015,W3615,W361524,W3018,W3618,W361824

ASSEMBLY INSTUCTIONS

Getting started:

Prepare a solid surface with protection layer to assemble on.

STEP 1: Join side panel with back panel.

STEP 2: Join side panels with back panel and attach top panel for support.





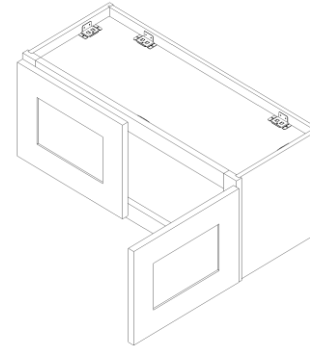

STEP 3: Join bottom panel with side panels and back panel.

STEP 4: Attach face-frame to side, top and bottom panels.

STEP 5: Fix door onto the face-frame and adjust the cover-space.

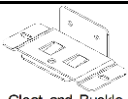

PARTS LIST		
NO.	Description	QTY
1	FACE FRAME	1
2	BACK PANEL	1
3	SIDE PANEL	2
4	TOP&BOTTOM PANEL	2
5	CABINETS DOOR	2

7	1 1/2" SOFTCLOSE HINGE	4	 1 1/2" hinge
6	3/4" ROUND HEAD SCREW	4	 3/4" round head screw
5	BUMPER	4	 Bumper
4	DAMPER	2	 Damper
3	9/16"ROUND HEAD SCREW	70	 9/16" round head screw
2	CLEAT AND BUCKLE	14	 Cleat and Buckle
1	1"FLAT HEAD SCREW FOR CARCASS	8	 1" flat head screw
NO.	Description	QTY	PICTURE

HARDWARE LIST

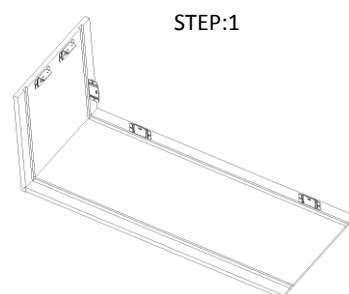

STEP:1

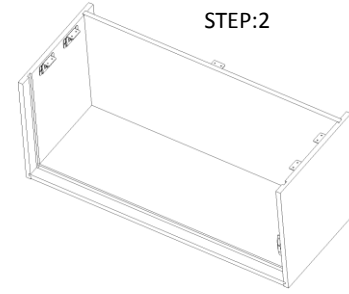

STEP:2

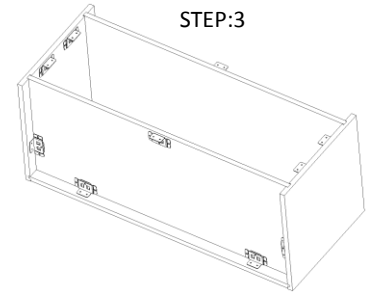

STEP:3

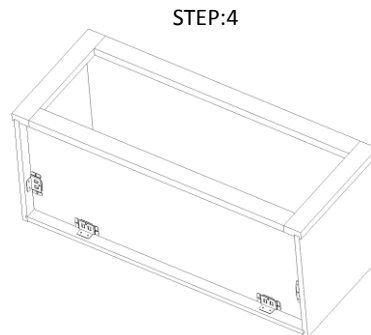

STEP:4

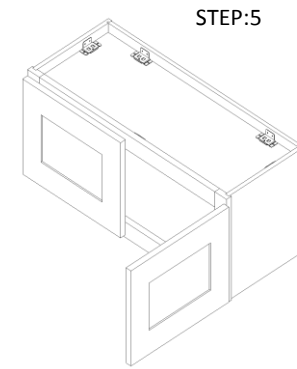

STEP:5

How To Fix Soft Close Hinge

