

VKD36

ASSEMBLY INSTUCTIONS

Getting started:

prepare a protection layer, a screwdriver

STEP 1: Join side panel with back panel.

STEP 2: Join side panel with back panel.

STEP 3: Attach face-frame.





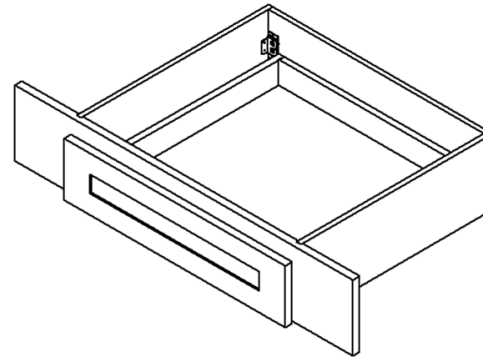

STEP 4: Attach the wooden corner blocks on the top corners.

STEP 5: Join the drawer together, then install the drawer guide.

STEP 6: Fix drawer head on the drawer front and adjust the cover-space.

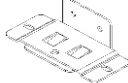

PARTS LIST		
NO.	Description	QTY
1	FACE FRAME	1
2	DRAWER BOX BOTTOM	1
3	DRAWER BOX SIDE	2
4	DRAWER BOX FRONT AND BACK	2
5	BACK PANEL	1
6	SIDE PANEL	2
7	DRAWER HEAD	1

7	BUMPER	4	 Bumper
6	1" ROUND HEAD SCREW	4	 1" round head screw
5	18" SELFCLOSE SLIDE	1	 Selfclose slider
4	9/16" ROUND HEAD SCREW	20	 9/16" round head screw
3	CLEAT AND BUCKLE	4	 Cleat and Buckle
2	WOOD BLOCK	4	 Wood block
1	1" FLAT HEAD SCREW FOR WOOD BLOCK	8	 1" flat head screw
NO.	Description	QTY	PICTURE

HARDWARE LIST

STEP:1

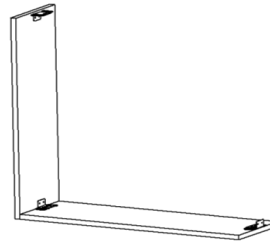

STEP:2

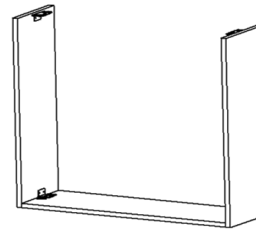

STEP:3

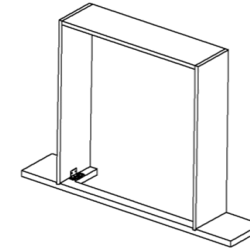

STEP:4

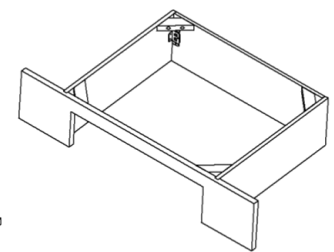

STEP:5

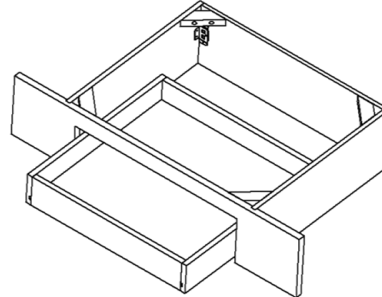

STEP:6

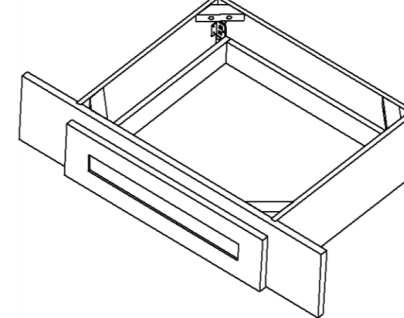

Full extension concealed drawer runners

