

# DFB18

## ASSEMBLY INSTUCTIONS

### Getting started:

Prepare a solid surface with protection layer to assemble on.

STEP 1: Join side panel with back panel.

STEP 2: Join bottom panel with side panel.

STEP 3: Join side panel with bottom and back panel.









STEP 4: Attach face-frame and toekick board.

STEP 5: Join the drawers together, then install the drawer guides.

STEP 6: Attach the wooden corner blocks on the top corners.

STEP 7: Fix drawer heads on the drawer fronts.

PARTS LIST		
NO.	Description	QTY
1	FACE FRAME	1
2	DRAWER BOX BOTTOM	2
3	DRAWER BOX SIDE	2
4	DRAWER BOX SIDE	2
5	DRAWER BOX FRONT AND BACK	2
6	DRAWER BOX FRONT AND BACK	2
7	BACK PANEL	1
8	TOP&BOTTOM PANEL	1
9	SIDE PANEL	2
10	TOE KICK	1
11	DRAWER HEAD	1
12	DRAWER HEAD	1

8	BUMPER	8	 Bumper
7	1" ROUND HEAD SCREW	8	 1" round head screw
6	Selfclose slider	2	 Selfclose slider
5	9/16" ROUND HEAD SCREW	50	 9/16" round head screw
4	CLEAT AND BUCKLE	10	 Cleat and Buckle
3	1" FLAT HEAD SCREW FOR CARCASS	2	 1" flat head screw
2	WOOD BLOCK	4	 Wood block
1	1" FLAT HEAD SCREW FOR WOOD BLOCK	8	 1" flat head screw
NO.	Description	QTY	PICTURE

### HARDWARE LIST

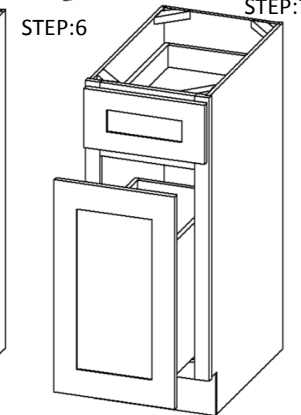
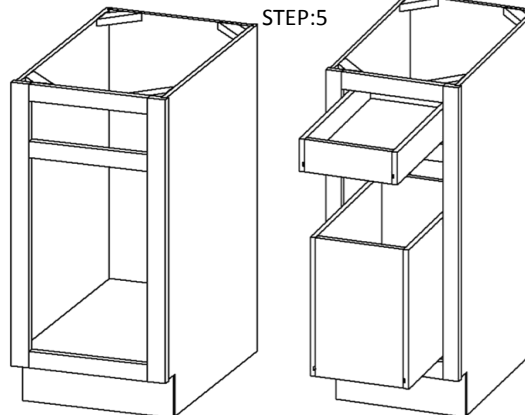
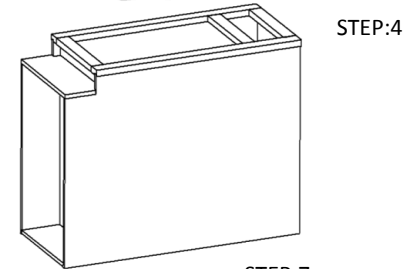
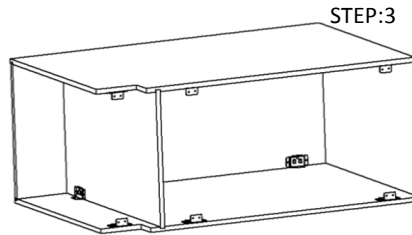
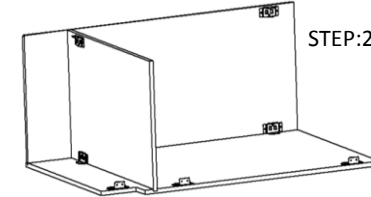
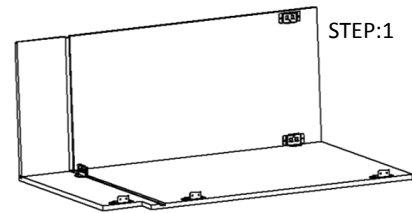
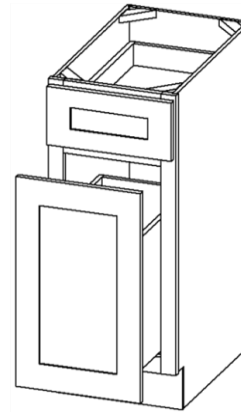

Full extension concealed drawer runners

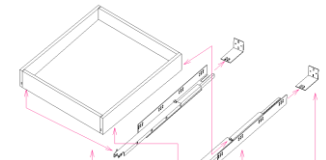

Drawer box  
Locking devices  
Runner profiles  
Rear mounting brackets(for frame applications)