

# DCW2430,DCW2436,DCW2442

## ASSEMBLY INSTRUCTIONS

Getting started:

Prepare a solid surface with protection layer to assemble on.

STEP 1: Join side panel with front face-frame.

STEP 2: Attach top panel with front face-frame and side panel.

STEP 3: Attach bottom panel with front face-frame and side panels.





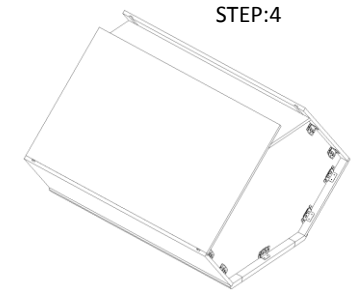
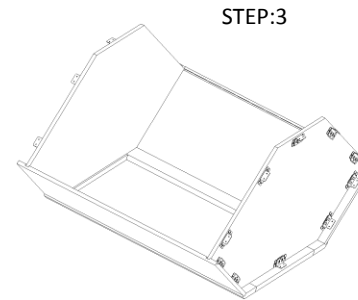
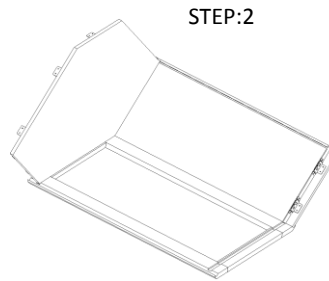
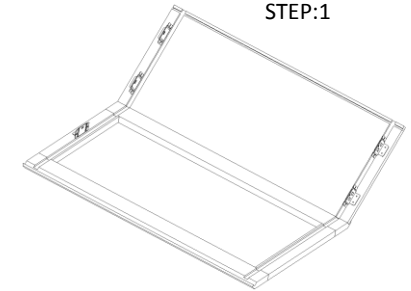
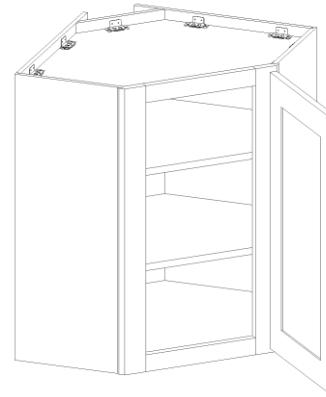

STEP 4: Attach back panel on top and bottom panels, then attach back side panels to top and bottom panels.

STEP 5: Put in the adjustable shelves.

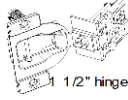
STEP 6: Fix door on to front face-frame and adjust the cover-space.

PARTS LIST		
NO.	Description	QTY
1	FACE FRAME	1
2	BACK PANEL	1
3	ADJUSTABLE SHELF	2
4	BACK PANEL	2
5	SIDE PANEL	2
6	TOP&BOTTOM PANEL	2
7	CABINETS DOOR	1

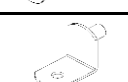

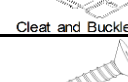
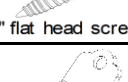
9	1 1/2" SOFTCLOSE HINGE	2	
8	3/4" ROUND HEAD SCREW	2	
7	BUMPER	2	
6	DAMPER	1	
5	SHELF CLIP	10	
4	9/16" ROUND HEAD SCREW	114	
3	CLEAT AND BUCKLE	22	
2	1" FLAT HEAD SCREW FOR CARCASS	6	
1	135 DEGREE ANGLE	2	
NO.	Description	QTY	PICTURE

### HARDWARE LIST

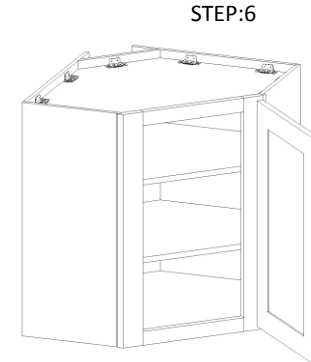
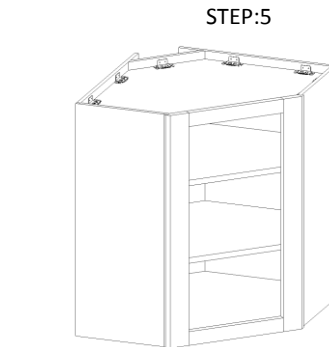

### How To Fix Soft Close Hinge

